



# C100 Wheel Balancer

All wheel balancers supplied by Concept Garage Equipment have been designed and manufactured with durability, affordability and safety in mind.

Our C100 wheel balancer has been designed to be busy and to fit in confined spaces. This wheel balancer is ideal for mobile tyre vans or smaller workshops. This is a great alternative to one of our motorised wheel balancers from our range. The C100 is also a great cost saver in terms of being a manual spin with no need for a motor. This machine is a hand operated machine but still comes with additional features that you would expect in a wheel balancer costing significantly more. This machine benefits from a two-year parts and labour warranty giving you the confidence that you are purchasing a reliable wheel balancer.

All our wheel balancers have been tested and certified to CE standards.

## FEATURES

- Manual spin
- Manual width and distance measuring
- ALU balancing mode at 9 o'clock or 12 o'clock positions to add balance weights
- Statistic and dynamic balancing, 7 ALU mode programs for alloy rims or special shaped rims
- Aluminium ruler head to 24" rims
- Footbrake for safe stopping
- Motorcycle balance mode
- Self-diagnosis for easy problem solving
- Apply steel and aluminium rim
- Perfect for mobile tyre fitting / Ideal for confined spaces
- 2 years warranty – year 1 parts and labour / year 2 parts only

## TECH DATA

|                                   |                       |
|-----------------------------------|-----------------------|
| Max wheel weight:                 | 65 kg                 |
| Power supply:                     | 240 V                 |
| Balancer cycle time:              | 7 seconds             |
| Wheel Dimension:                  | 10"–24"               |
| Rim Width:                        | 1.5"–20"              |
| Wheel balancer operational noise: | <70 dB                |
| Dimensions:                       | 786mm x 455mm x 903mm |

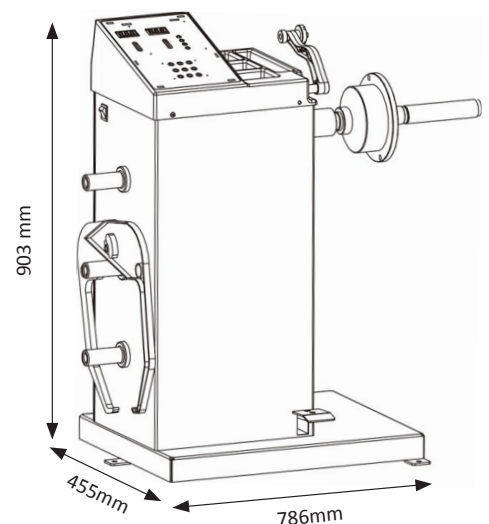

[www.concept-ge.co.uk](http://www.concept-ge.co.uk) ● [info@concept-ge.co.uk](mailto:info@concept-ge.co.uk) ● Call 01302 203 888

Why not visit our showroom located in Doncaster, South Yorkshire, and see the quality for yourself before you purchase. Please request more details or book an appointment. Unit 4, Westmoor Park Network Centre, Doncaster DN3 3GW.